



50Ω TERMINATED 3 GHz SMA N/O S.P.3 T. SWITCH

OPTIONS : INDICATOR / TTL DRIVE / SUPP.DIODES

R F CHARACTERISTICS

NUMBER OF WAYS : 3
FREQUENCY RANGE : 0 - 3 GHz
IMPEDANCE : 50 Ohms

FREQUENCY (GHz)	0 - 3
V.S.W.R <=	1.20
INSERT. LOSS <=	0.20 dB
ISOLATION >=	80 dB
AVER. POWER (*)	120 W

TERMINATION IMPEDANCE : 50 Ohms
TERMINATION AVG. POWER AT 25°C : 1 W per termination
3 W total power

ELECTRICAL CHARACTERISTICS

ACTUATOR : NORMALLY OPEN
NOMINAL CURRENT AT 25°C (±10%) : 250 mA
ACTUATOR VOLTAGE (Vcc) : 12V (10.2 to 13V) / NEGATIVE COMMON
TERMINALS : solder pins (250°C max./30 sec.)
INDICATOR RATING : 1 W / 30 V / 100 mA
TTL INPUTS (E) - High level : 2.2 to 5.5V / 800µA at 5V
- Low level : 0 to 0.8V / 20µA at 0.8V

MECHANICAL CHARACTERISTICS

CONNECTORS : SMA female per MIL-C 39012
LIFE : 2.000.000 cycles per position
SWITCHING TIME (nominal voltage;25°C) : < 15 ms
CONSTRUCTION : splashproof
WEIGHT : < 250 g

ENVIRONMENTAL CHARACTERISTICS

OPERATING TEMPERATURE RANGE (°C) : -40 , +85
STORAGE TEMPERATURE RANGE (°C) : -55 , +85

(* : average power at 25°C per RF path)

This information is given as an indication. In the continual goal to improve our products, we reserve the right to make any modifications judged necessary

DRAWING

General tolerance: ± 0,5 mm

R574 312320

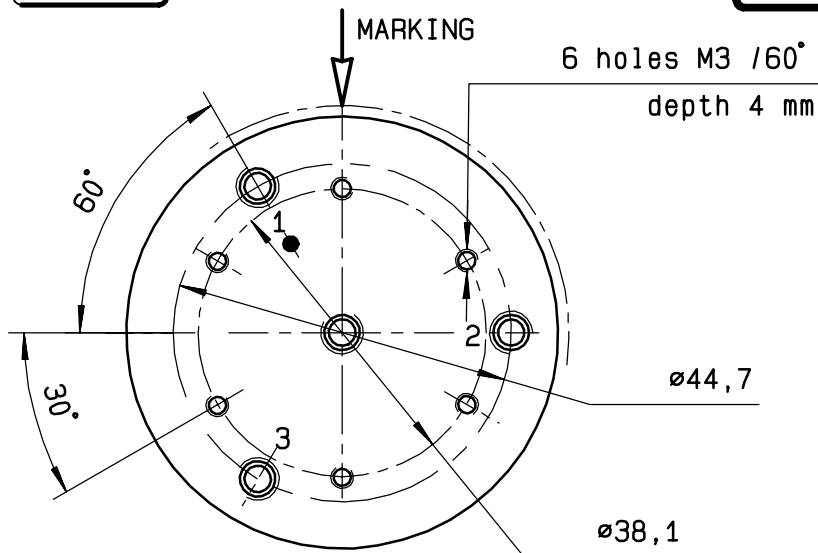

TTL input	RF continuity	Ind.
E1 = 1	IN ↔ 1	D.E
E2 = 1	IN ↔ 2	D.F
E3 = 1	IN ↔ 3	D.G

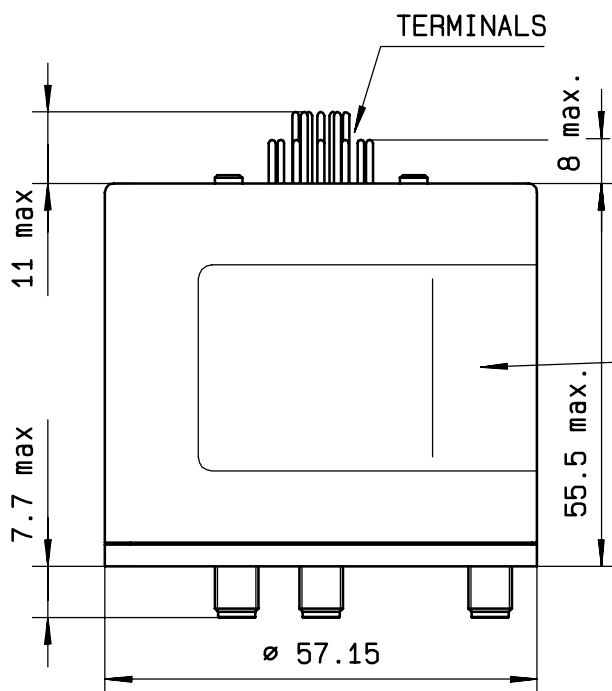

TOP VIEW (TERMINALS)

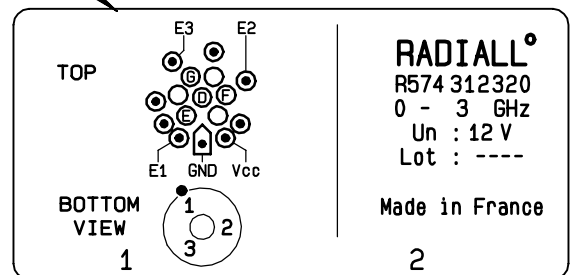

SCHEMATIC DIAGRAM

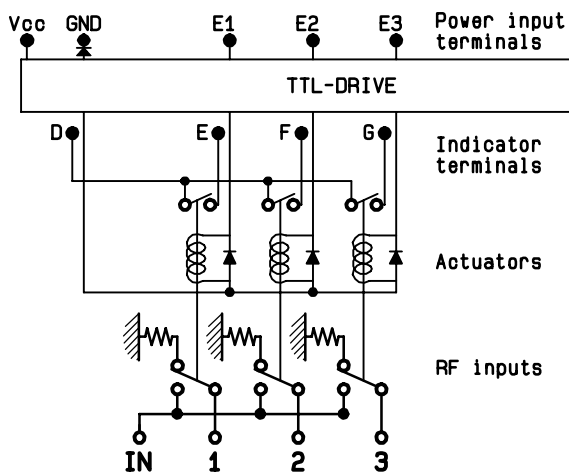

4113-9212 This information is given as an indication. In the continual goal to improve our products, we reserve the right to make any modifications judged necessary